

SRT02EA ELECTRONIC THERMOSTAT

DESCRIPTION

SRT02EA electronic thermostats are mainly used in central air-conditioning and cooling/heating system, it can keep suitable temperature according to the set temperature point.



CHARACTERISTICS

- Super small design, simple and lively
- Suitable for internal or external sensor
- Use high quality components, accurately temperature control and stable
- Flexible installation: wall-mounted, embedded, embedded in plate or concealed

SPECIFICATIONS AND TECHNICAL DATA

PRODUCT NAME	SRT02EA Electronic thermostat
FUNCTION	Relay output to control motor and motorized valve
USE	Used in temperature control in heating / cooling air-conditioning system
POWER SUPPLY	220V AC $\pm 10\%$, 50/60 Hz
OUTPUT SIGNAL	Relay output (1A/250V) on/off signal
CONSUMPTION	5VA without load
SENSITIVE ELEMENT	NTC thermistor
PRECISION	$\pm 0.5^{\circ}\text{C}$
WIRING	Terminal connection, 1.5mm ² wiring screws
HOUSING	Fire-proof ABS engineering plastic
WORKING ENVIRONMENTAL RANGE	0 ~ +50 $^{\circ}\text{C}$ and 10 ~ 90% RH non-condensation
STORAGE TEMPERATURE RANGE	-40 ~ +70 $^{\circ}\text{C}$
NET WEIGHT	70g

DIMENSIONS

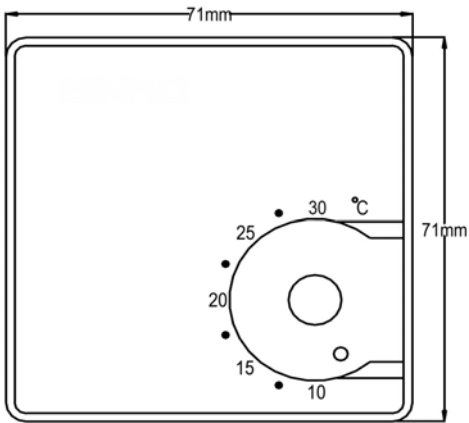

WIRING DIAGRAM

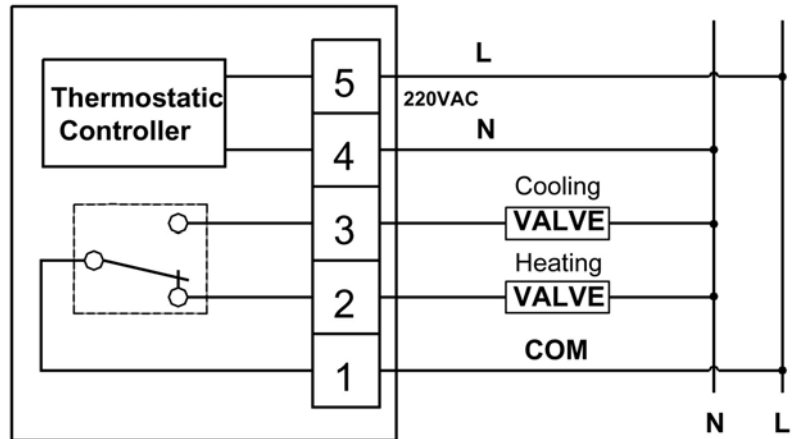

INSTALLATION DIAGRAM

